



CREATIVE CONCRETE

Innovation in concrete since 1999

Ballinamere, Tullamore, Co. Offaly.

R35 P866

Tel: 057 9355808

Fax: 057 9355558

Email: info@creativeconcrete.ie

Website: www.creativeconcrete.ie

MANUFACTURES OF:

Approved Utility Chambers - ESB Mini-Pillar Vault -

Eir-Virgin Media - Public Lighting - TV / CCTV.

Irish Water - FLORITE Private Side Inspection Chamber,

Sluice Valves, Fire Hydrant and Air Valve Chamber.

**AIR VALVE CHAMBER
STD-W-20**

APPROX. WEIGHT: 545 Kg

BASE - 185 Kg,
CHAMBER - 360 Kg.

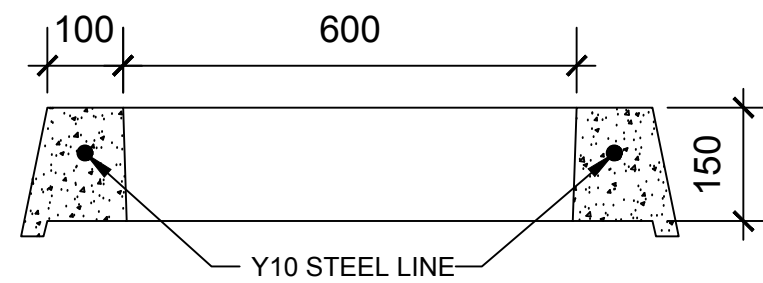

RISER SECTION VIEW

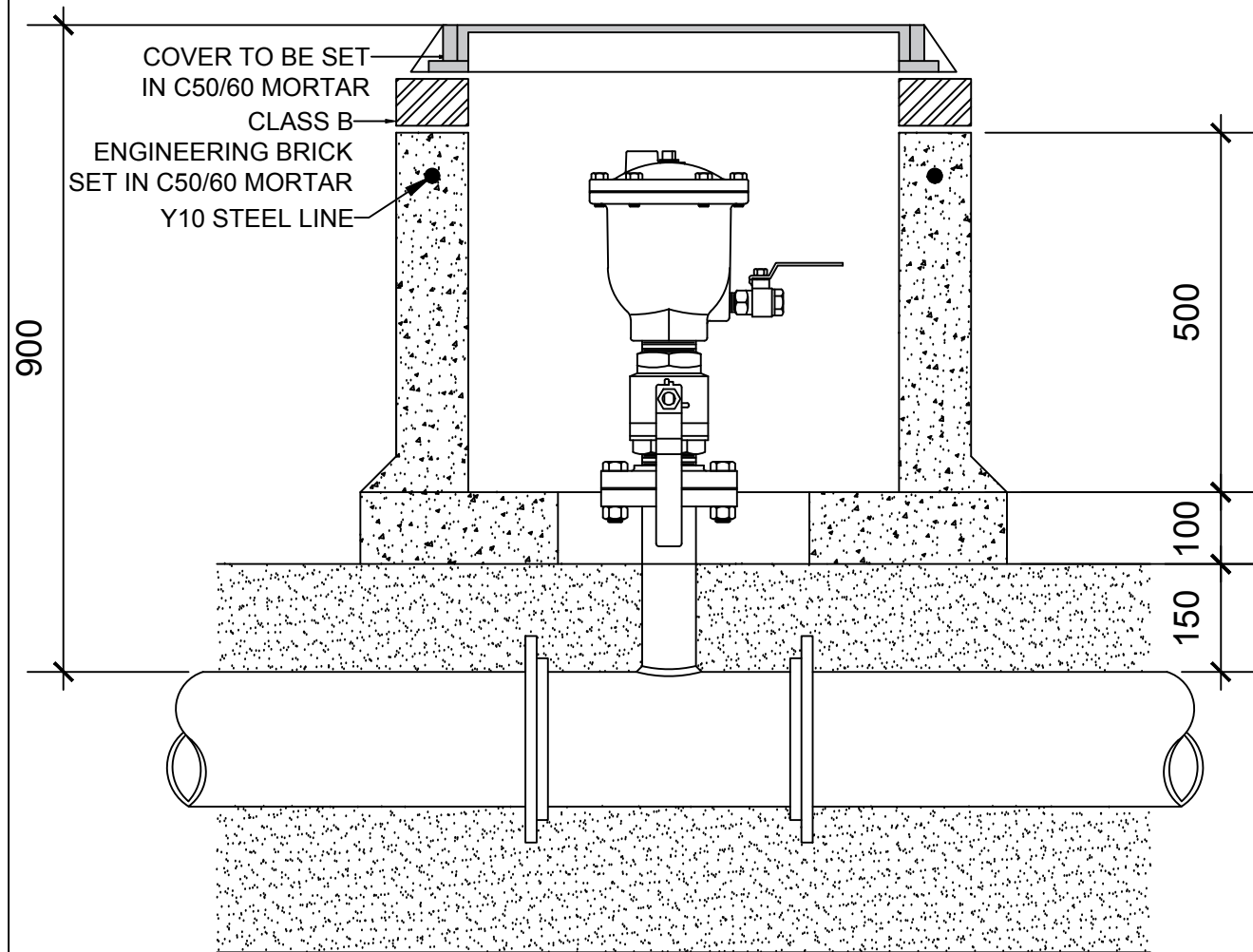
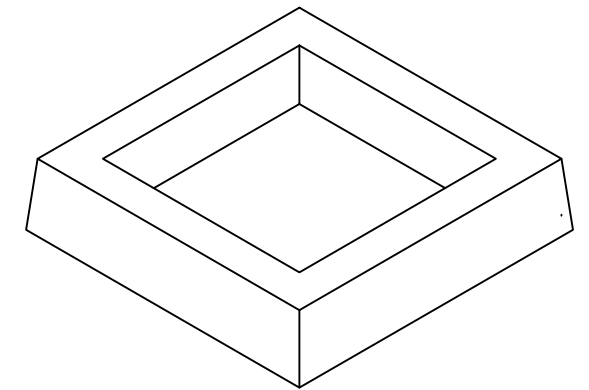

SECTION VIEW: UNTRAFFICED MIN. 900mm.

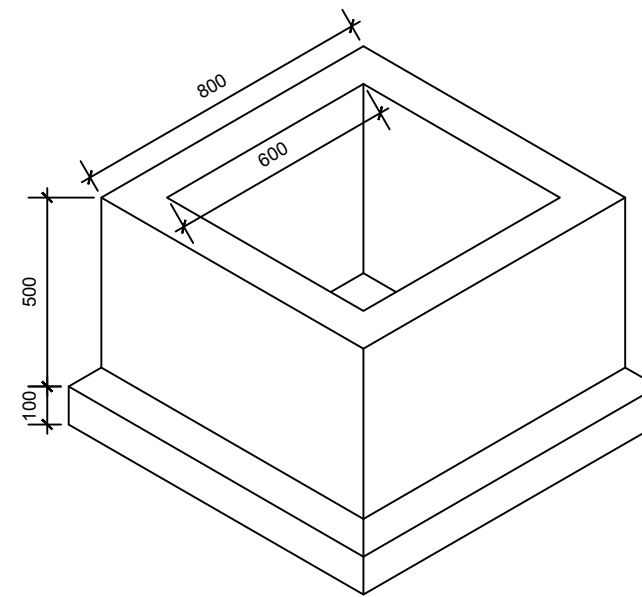

BASE AND CHAMBER CAST MONOLITHIC

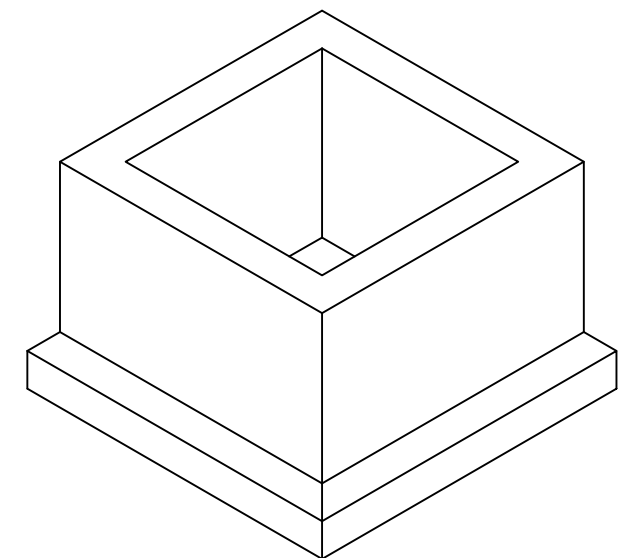

THE INFORMATION CONTAIN IN THIS DRAWING WAS UP TO DATE AT TIME OF GOING TO PRINT. PROFILES, SIZES, WEIGHTS ARE GIVEN AS AN INDICATION ONLY. **CREATIVE CONCRETE** RESERVES THE RIGHT TO MODIFY THESE AT ANY TIME WITHOUT NOTICE.