

**SECTION VIEW A-A: SLUCE VALVE CHAMBER COMPLETE 150mm COVER.**

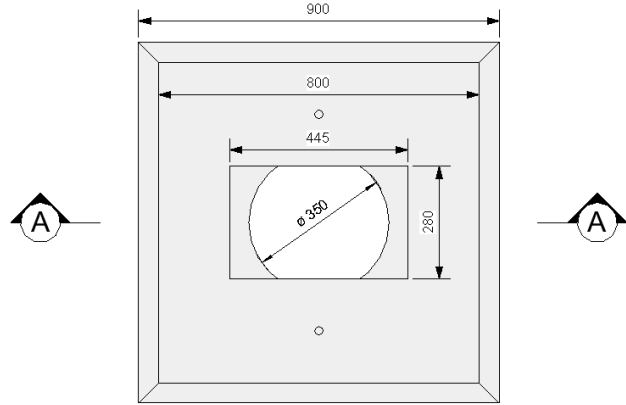

**PLAN VIEW: SLUCE VALVE CHAMBER COMPLETE WITH 150mm COVER.**

## CONFIDENCE IN CONCRETE

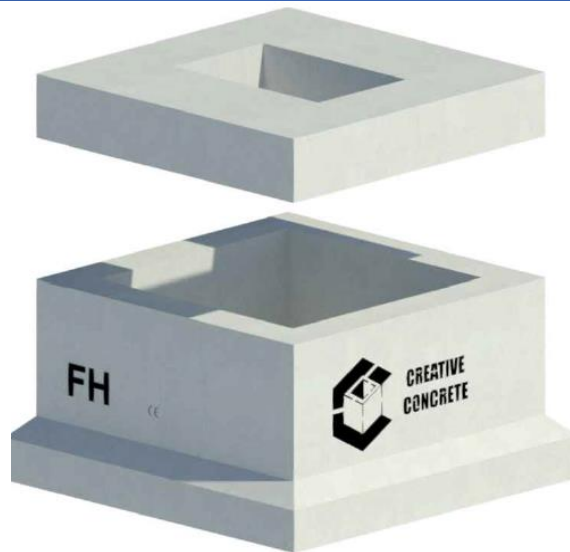

**3D IMAGE: FIRE HYDRANT CHAMBER COMPLETE WITH 150mm COVER.**

TECHNICAL DATA	
Mechanical Resistance	Vertical Strength 400kN
Weight	440KG
Opening Size	(LN x WN) 600mm, 600mm Square
Watertightness	No Leakage of joint or unit at 30kPa
Durability	Adequate for normal serviceability conditions

FEATURES	
Integrated Base Opening	✓
Manufactured to the highest standards.	✓
Steel Reinforced	✓
Integrated Steps	
Integrated Lifting pins	✓
REV_03	

All Products are manufactured in compliance with EN 1917:2002&AC:2008 Concrete Manholes and Inspection Chambers Un-Reinforced, Steel, Fibre, And Reinforced. The information contained in this TDS was up to date at time of going to print. Profiles, sizes, weights are given as an indication only. The manufacturer reserves the right to modify these at any time without notice.

